

Blade configuration (cross section)

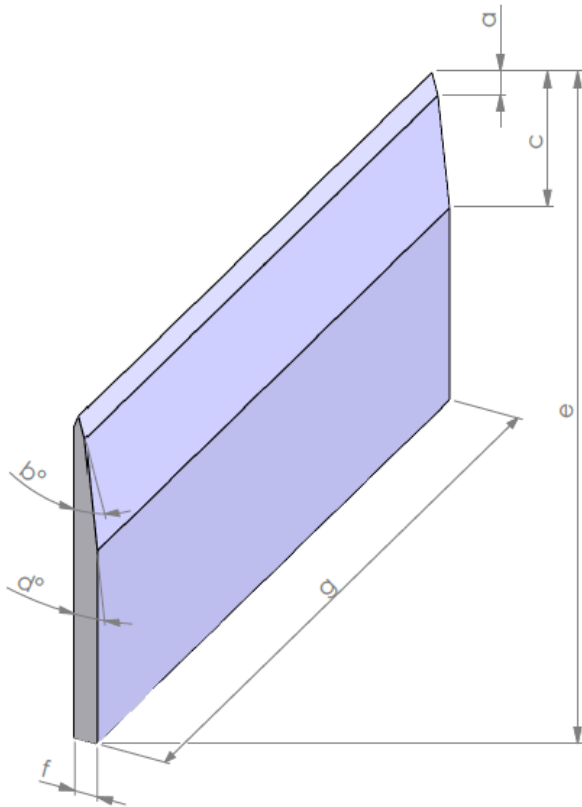

- a honing width
- b honing angle
- c grinding width
- d grinding angle
- e height of blade
- f thickness of blade
- g length of blade

Blade type (cross section)

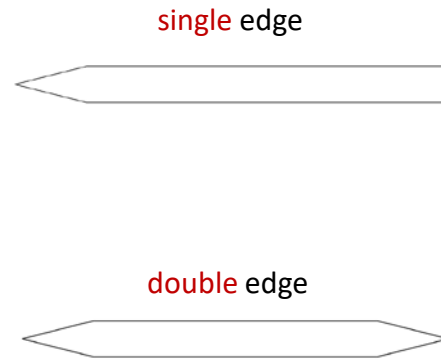

Cutting edge (cross section)

